

NEURAL NETWORK BASED ADAPTIVE CONTROL SYSTEM FOR AIRCRAFTS

V. A. Apostolyuk¹, A. I. Dovgan²,

¹ National Aviation University, Institute of Aerospace Control Systems
Prospect Komarova 1, 03680, Kiev, Ukraine, e-mail: vladislav@apostolyuk.com

² National Technical University of Ukraine "Kiev Polytechnical Institute", Aerospace Systems Faculty
Prospect Peremogy 37, 03056, Kiev, Ukraine, e-mail: comrade_a@ukr.net

Introduction

The problem of automatic control systems development for complex dynamic objects (in particular, aircrafts under influence of environmental disturbances) is characterized by transition from a paradigm of adaptive control to a paradigm of intellectual control [1, 2]. The reasons for this are: objects to be controlled and conditions of their performance continuously becoming more complicated, new classes of means for calculation being discovered (in particular, the distributed computing systems), requirements to accuracy and speed of control systems performance under conditions of uncertainty or the incomplete input information being increased.

Application of neural networks allows to remove mathematical problems of analytical synthesis and analysis of designed system properties [3].

The objective of this paper is to research the designed control system robustness to change of control object's parameters (engine thrust, aircraft mass, shift centre of gravity, change of the wing area) as well as to define the optimal genetic algorithm's parameters which will minimize altitude control error and time of transient process when the aircraft changes to another flight echelon.

Control algorithm structure

The general scheme of system structure and operation is shown in Figure 1. The multilayered neural network has been chosen for construction of neural controllers NN1 and NN2 [4]. The architecture of a neural network: network of direct signal transmission, which consists of input, output and two hidden layers. The network structure is identical for each channel – 2 inputs, 15 neurons in the first hidden layer, 15 neurons in the second hidden layer and 2 outputs neurons. The neural network training was conducted by genetic algorithm.

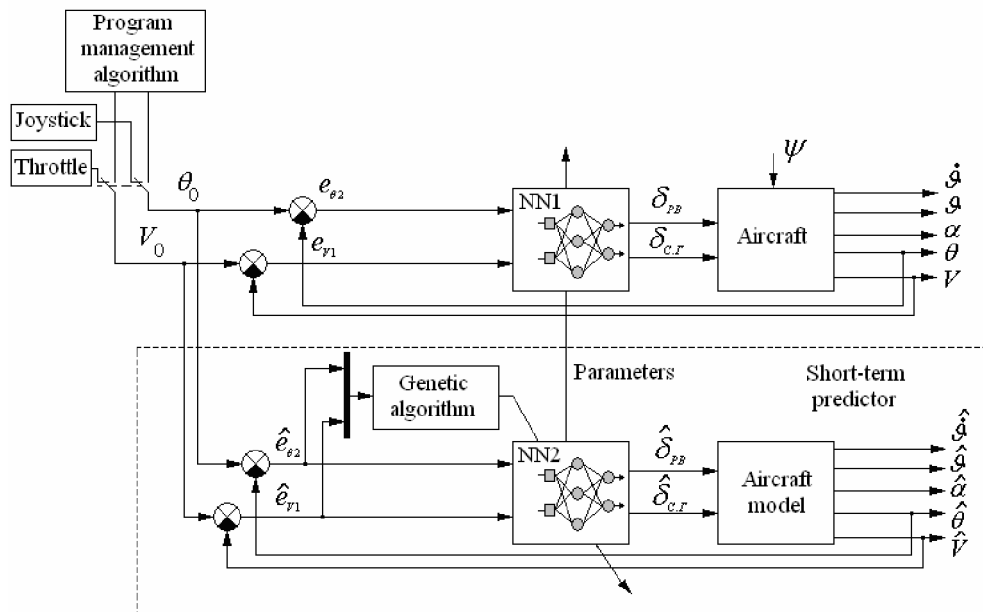

Fig. 1. General structure of the control system

The following concept of adaptive control system performance is proposed. The system consists of two channels: the channel of a direct control and the virtual channel. In the direct channel neural controller NN1 stabilises aircraft at desired input flight trajectory angle and airspeed. In the virtual channel aircraft behaviour is predicted for the certain time range (prediction horizon). Prediction horizon is assumed at 5 sec.

Desired aircraft airspeed and trajectory slope angle are provided from the tactical level of control either by the pilot or control program algorithm. Control at the execution level is aimed at stabilization of the airspeed and flight trajectory angle. The control performance criterion is based on the least squares of the control errors, which is also used to calculate the fitness function for the genetic algorithm.

Calculations of fitness function for each chromosome in the population is performed. In this case, evolution termination criteria are not checked – genetic operators are applied and the new generation is produced.

At a following stage optimization parameters are copied to the neural controller NN1. Controller NN1 produces throttle and elevator control to provide the desired flight trajectory angle and airspeed. Control algorithm operation is demonstrated by the flow-chart diagram in Figure 2.

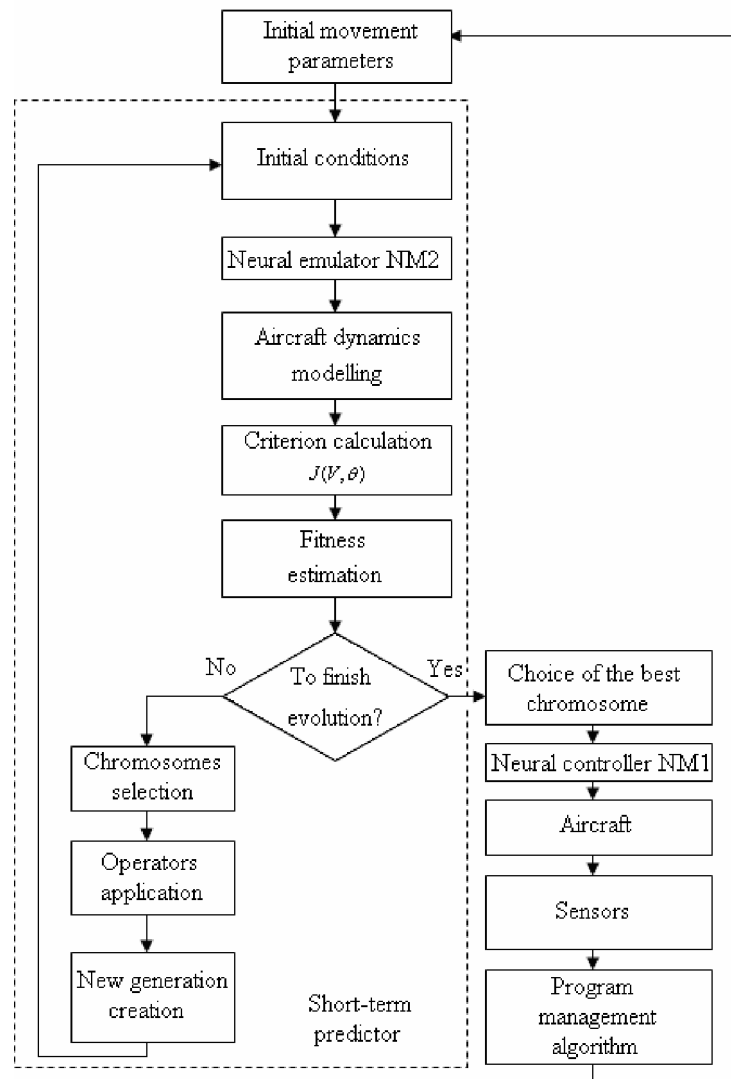

Fig. 2. Algorithm operation flow-chart

Control system optimization

Optimization of control system consists of studying influence of genetic algorithm's parameters on control error and transient time of flight trajectory angle. System behaviour is evaluated as a reaction to the several pulses applied as an input. Research is executed for genetic algorithm with the following ranges of parameters probabilities: cross-over: 0,5 – 0,95; mutation: 0,05 – 0,4; inversion: 0,01 – 0,45. The analysis of results has shown that optimal values of genetic algorithm parameters are as follows: cross-over – 0,9; mutation – 0,1; inversion – 0,05. The specified parameters minimize error of flight path angle and transient time. System response on test pulse in terms of the flight path angle is shown in figure 3.

System performance under parameters variation

Numerical modelling of system operation has been made for the altitude – 1000 m and airspeed – 120 m/s. Characteristics of jet fighter F-15(eagle) were used as parameters of aircraft model [5]. Simulation results for maintaining constant altitude are shown in figure 4.

Sudden change of altitude during flight (vertical climb on 300 m on 18 sec and descent to 300 m on 38 second) is shown in figure 5. Dryden's model was used as wind model.

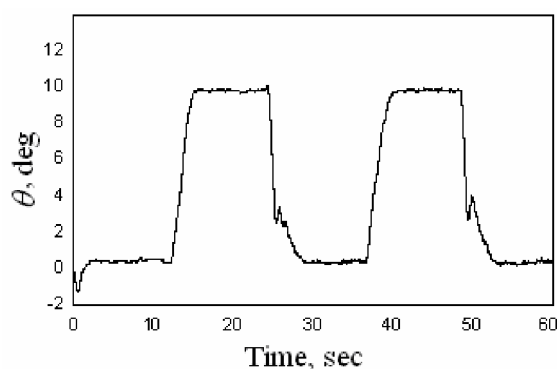

Fig. 3. Flight path angle as a function of time

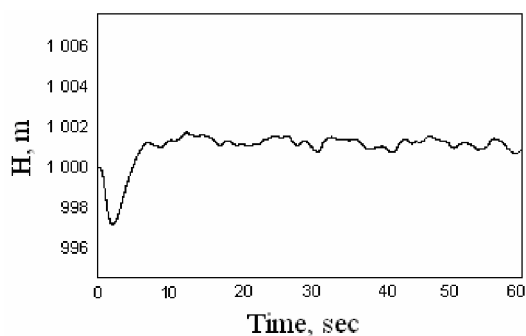

Fig. 4. Maintaining constant altitude

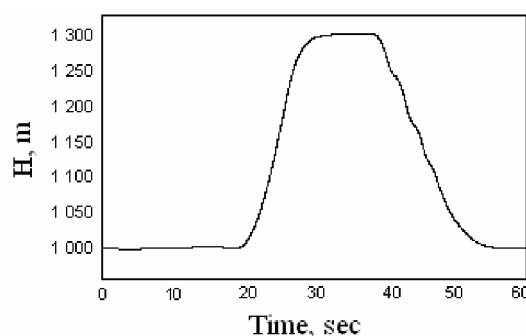

Fig. 5. Changing altitude

System performance research has been conducted for two cases: under the conditions of wind disturbances being absent and under presence of wind disturbances. Variable parameters are aircraft mass characteristics, the maximal engine thrust, change of the wing area, shift centre of aircraft gravity along the longitudinal axis. For an example, system response on test pulse when the aircraft weight has decreased for 10 and 25 percent (on 36 second) shown in figures 6 and 7.

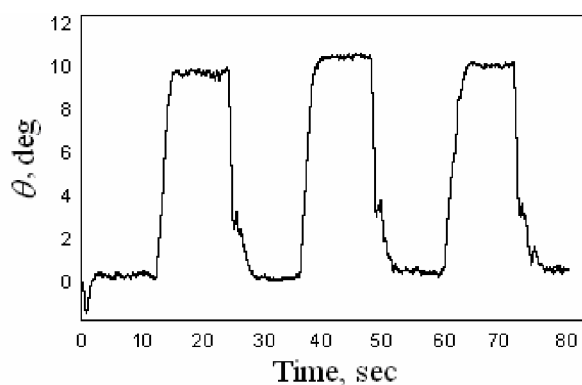

Fig. 6. Flight trajectory angle variations (0,9m)

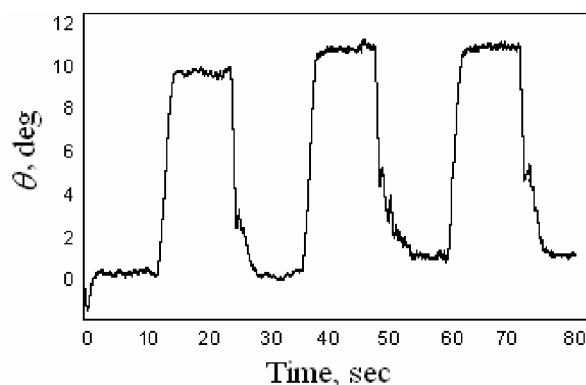

Fig.7. Flight trajectory angle variations (0,75m)

Conclusions

Suggested neural-network based aircraft control system concept demonstrated high robustness and excellent performance in realising desired flight trajectory angle and airspeed.

Optimal parameters of the genetic algorithm were identified to be as follows: crossover –0,9; mutation – 0,1; inversion: – 0,05. The specified parameters minimize error of flight trajectory angle and transient time. Henceforth, at the trajectory control level both minimization of altitude hold error and time of aircraft transition for another flight level occur. The following control performances were achieved: altitude stabilisation error 1.1 m, transient time - 12s. Obtained absolute error of altitude stabilisation does not exceed 3 m. The neural controller has appeared practically insensitive to action of wind disturbances at constant parameters of the plane.

Presented research demonstrated that both doubling aircraft weight and increasing it in one and a half time result in the maximal error of altitude stabilisation to remain within the 10 m tolerance. Reduction of thrust (up to 25 percent from initial) influences altitude stabilisation error within the range of 4 m.

Research of centre of gravity shifts influences shows, that at shift of ± 1 m the system remains stable on all modes of flight with satisfactory parameters of accuracy and quality of transient processes. In case of wing area variations within the range of 30 percent, error of altitude stabilisation does not exceed 10 m.

Most importantly, successful operation of the system and its capability to readjust to significant variations in aircraft parameters has been demonstrated.

As a future research, it is planned to modify genetic algorithm and to study neural networks structural adaptation as well.

References

1. Magni J.F. Robust Flight Control Design Challenge – London, Ltd. – 1997. – P. 649.
2. Antani J., Paden B.E. Award – winning Control Applications – IEEE Control Systems Magazine. –vol. 22. – №6. – 2002 – P. 28.
3. Комашинский В. И., Смирнов Д. А. Нейронные сети и их применение в системах управления и связи. – М.: Горячая линия – Телеком, 2003. – 94 с.
4. Apostolyuk V.O., Apostolyuk O.S.. Fundamentals of flight control theory. Aircraft automatic flight control system calculation: Term Paper Method Guide, Kyiv: NAU, 2009. – P. 30.
5. A.I. Dovgan, V.O. Apostolyuk. Neural-Network Based Aircraft Control System Optimisation // Information Systems, Mechanics and Control, No. 4, 2010, pp. 96-105.